

Duration 3hrs.

Marks 60

- NB
- 1) Question No. 1 is compulsory
  - 2) Attempt **any three** questions out of the remaining **five** questions.
  - 3) Figures to the right indicate full marks.
  - 4) Assume suitable data wherever required, but justify the same.

**Q1. Attempt any ONE**

**(15)**

**A.** Figure 1 shows an isometric view of a block. Draw the following:

**15**

- a) Sectional front view (F.V.) looking along arrow Y (Section B-B)
- b) Right-hand side view(R.H.S.V)
- c) Top View (T.V)

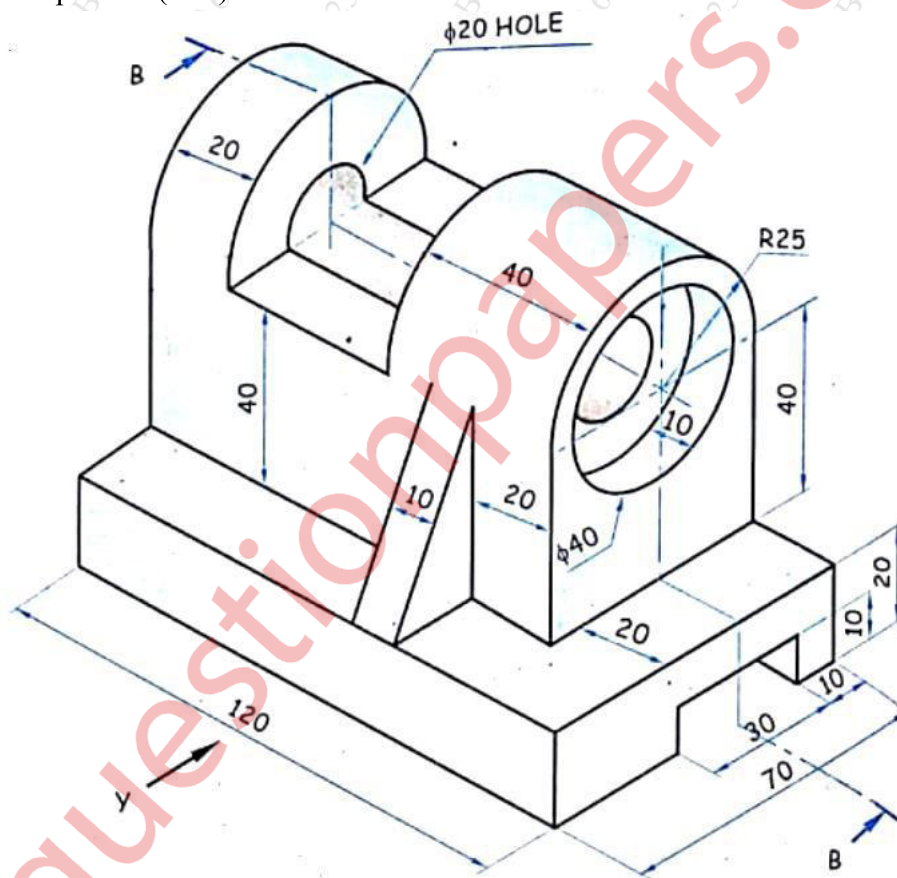

Figure 1

OR

**B.** Figure 2 shows an isometric view of a block. Draw the following:

**15**

- a) Sectional front view (F.V.) looking along Section A-A
- b) Left-hand side view(L.H.S.V)
- c) Top View (T.V)



- Q3** A. A hexagonal pyramid, side base of 30 mm and an axis 80 mm long, has its base edge 15 in the H.P. and parallel to V.P. Draw its projections if its apex is 50 mm above H.P.
- Q4** A. A hexagonal pentagonal prism, side of base 32 mm and an axis 70 mm long, has its 15 rectangular face on H.P. Its axis is parallel to H.P. and perpendicular to V.P. A cutting plane perpendicular to H.P. but  $45^\circ$  to the V.P. cuts its axis at a point 20 mm from the centre of the base. Draw its sectional front view, top view, Sectional side view and true shape of the section.
- Q5** A. Figure 4 shows two views of an object. Draw its isometric views with natural scale 9 and O as the origin.

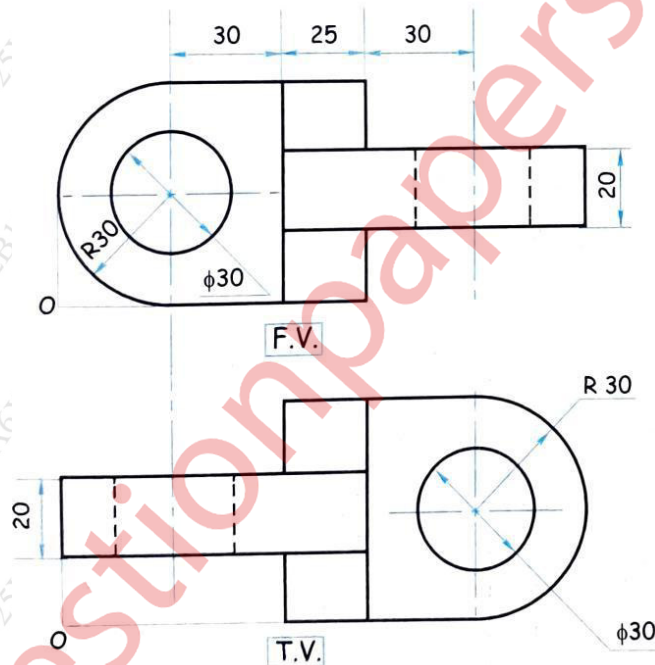

Figure 4 Two view of an object

- B.** A pentagonal plane of 25 mm side has one of its side in the H.P. Draw its projections, 6 if its surface is inclined at  $45^\circ$  to the H.P.
- Q6** A. The distance between the end projectors of a straight- line AB is 35 mm. The end A 9 is 10 mm above the H.P. and 20 mm in front of V.P. While end B is 45 mm above H.P. and 70 mm in front of V.P. Draw the projections of the line and determine its inclination with the H.P. and the V.P. Also, find the true length of the line.

- B. Figure 5 shows two views of an object. Draw its isometric views with natural scale 6 and O as the origin.

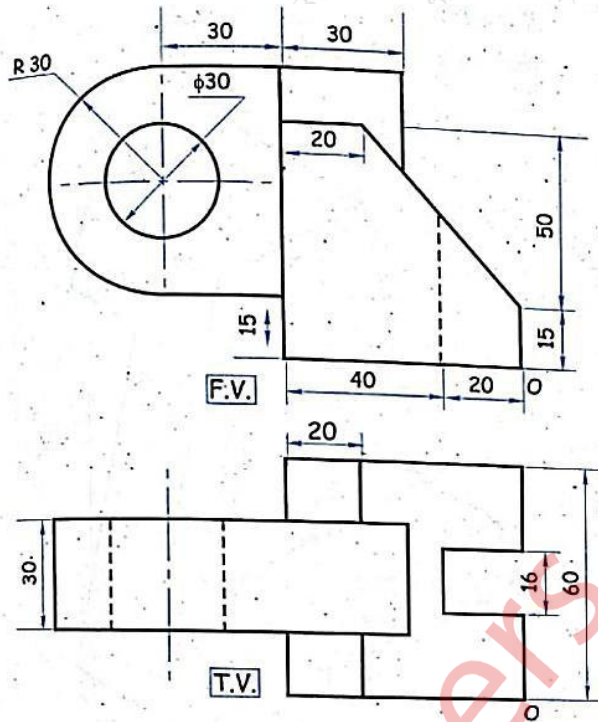

Figure 5 Two views of an object

\*\*\*\*\*