

Time: 2 hours

Marks: 60

N.B.:

- 1) Question No.1 is compulsory
- 2) Solve any three from remaining five.
- 3) Figures to right indicate full marks.

Q. 1 Attempt any five questions.

- A) Explain construction & working of N channel EMOSFET. [3]
- B) For a particular Op-Amp input offset current is 20 nA while input bias current is 60nA. Calculate the values of two input bias currents. [3]
- C) Differentiate between AC & DC load line. [3]
- D) Write short note on practical differentiator using operational amplifier [3]
- E) Compare ideal & practical characteristics of operational amplifier. [3]
- F) Determine V_{CE} for voltage divider bias circuit [3]

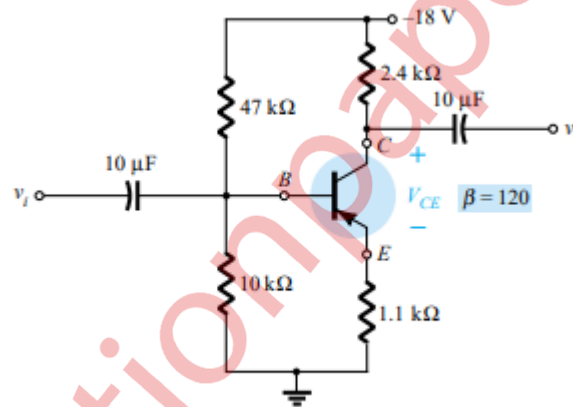

- Q. 2**
 - A) Design a high pass second order filter if cut off frequency 1KHz $C=0.01\mu\text{f}$ & Pass band gain is 2. [10]
 - B) Draw & explain the working of Wein Bridge Oscillator using operational amplifier [5]
- Q. 3**
 - A) Design the Astable Multivibrator using IC555 for a frequency of 1kHz & duty cycle of 70%. Use $C=0.1\mu\text{F}$. [10]
 - B) Design a voltage regulator using IC723 to give $V_o=15\text{ v}$ & output current of 500 mA. [5]
- Q. 4**
 - A) Design an adjustable voltage regulator using IC317 to give 15 volts at $I_L=100\text{mA}$, Given $I_{ADJ}=100\mu\text{A}$ choose $R_1=240\Omega$. [10]
 - B) Compare inverting & non inverting Schmitt trigger. [5]

Q. 5 A) Find input impedance, output impedance & voltage gain of given circuit. [10]

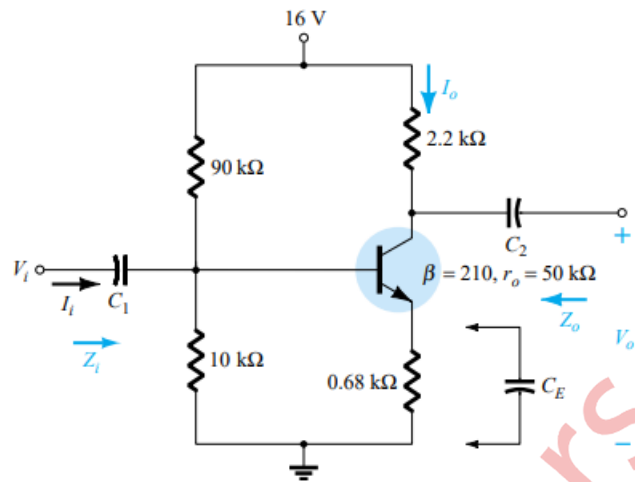

B) Explain the effect of coupling & bypass capacitor on the frequency response. [5]

Q. 6 Write short notes on: (Attempt any three)

- A) Block diagram of Operational Amplifier [5]
- B) BJT CE amplifier voltage divider bias circuit [5]
- C) IC 555 as Pulse Width Modulator [5]
- D) Miller theorem [5]